

3D View

Building		
Location		
Client:		
Project		
Model DWG		Date :
Status	Date	Name
Order		
Designer		
Detailer	17/2/2021	
Coating		
Material S275		
Scale 1:25	Project No.	Drawing Num. 100
<small>This drawing may not be copied, reproduced, or disclosed to third parties - This drawing was made with ADVANCE STEEL edited by Autodesk</small>		

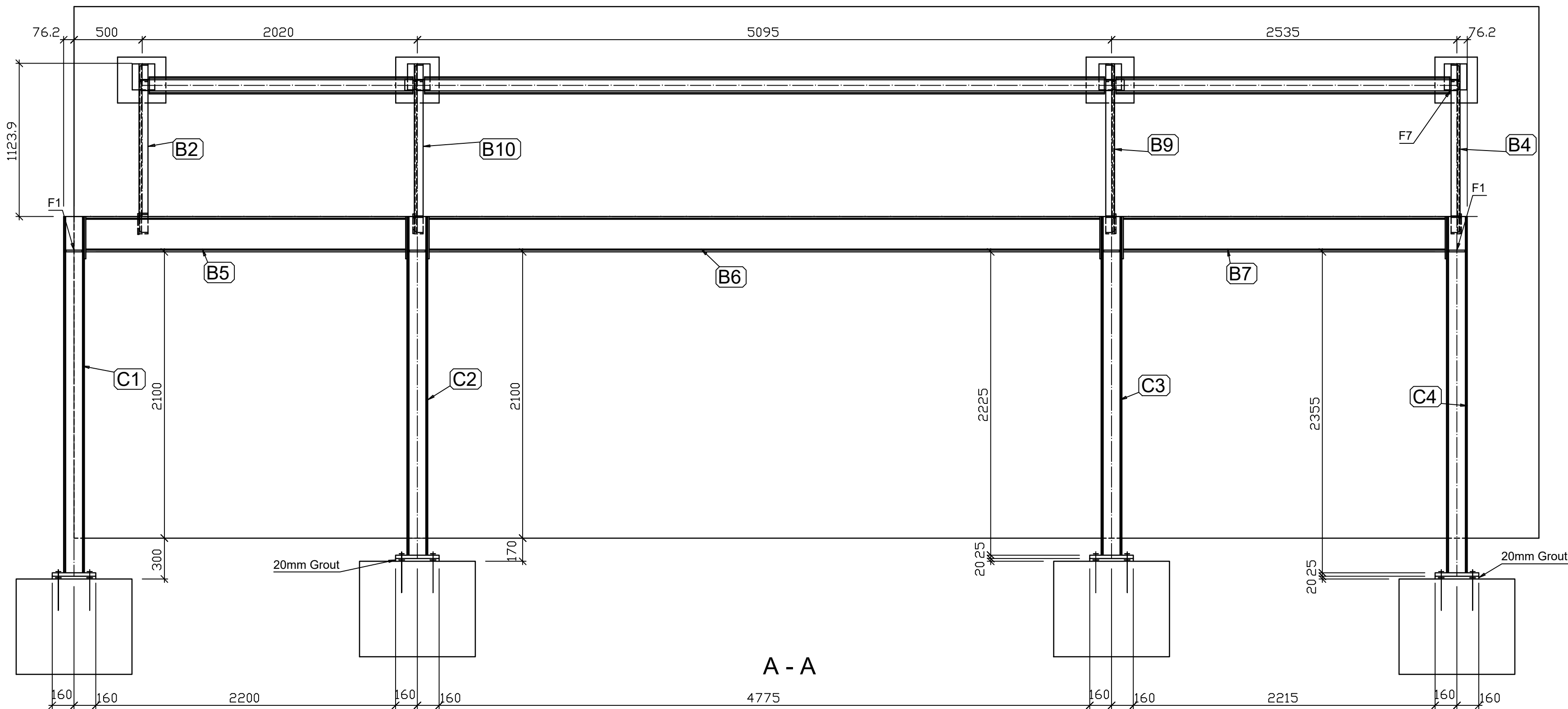

A - A

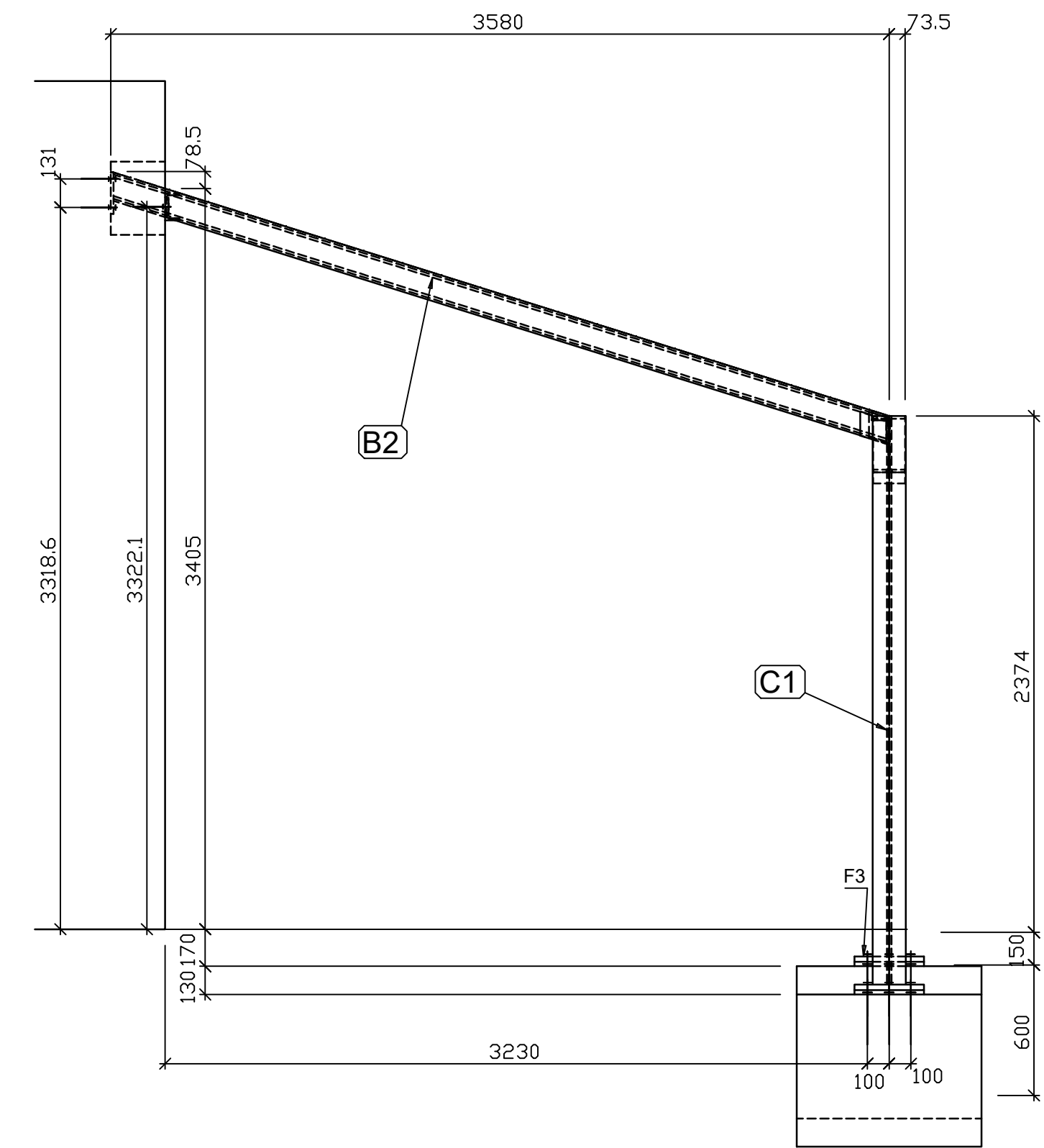

B - B

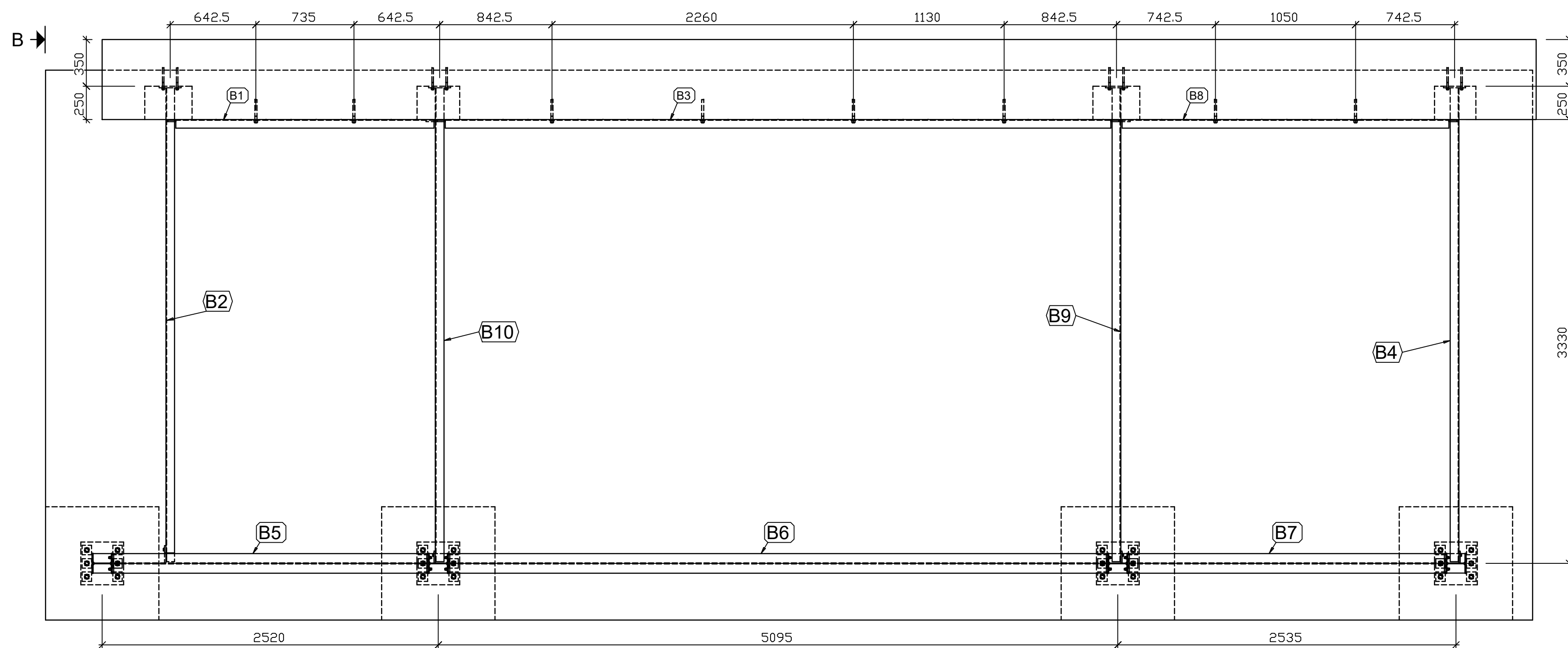

Base Plan

Building	
Location	
Client:	
Project	
Model DWG C:\...age\advance steel\3D.dwg	
Date :	
Status	Comment
Order	Date
Designer	Name
Detailer	14/2/2021
Coating	
Material	Autodesk®
S275	
Scale	
1:25	Project No.
	101
Drawing Num.	
101	
RevQ	
This drawing may not be copied, reproduced, or disclosed to third parties - This drawing was made with ADVANCE STEEL edited by Autodesk	

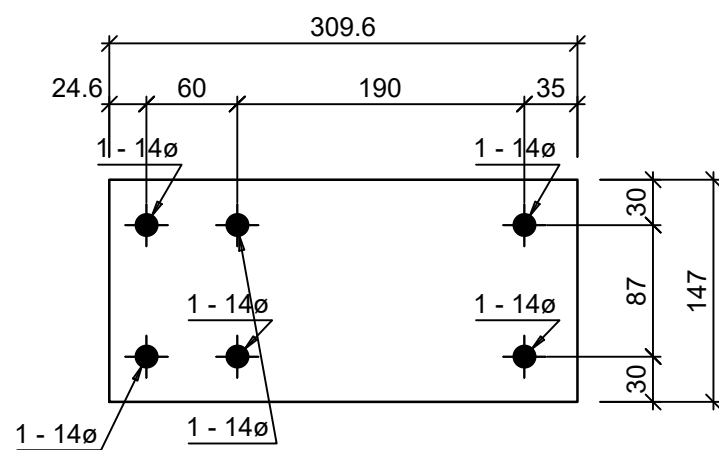

6 No. PLT10x147 - Mkd F2

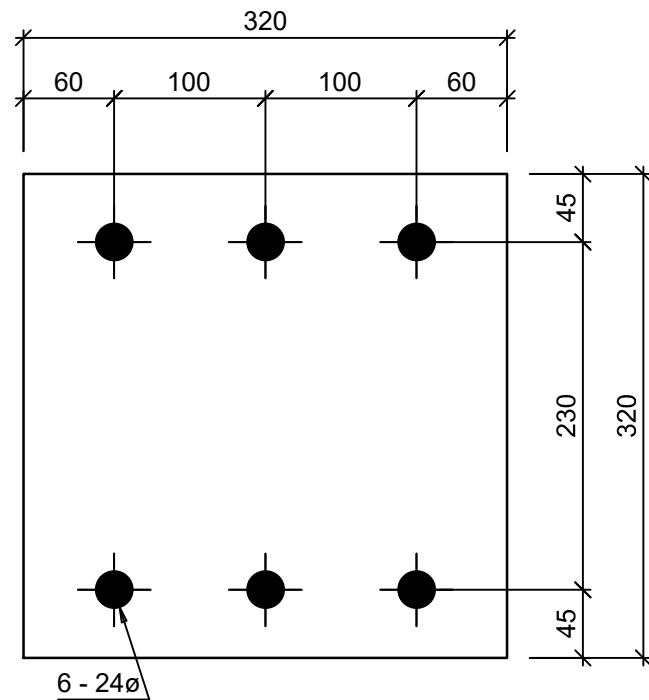

4 No. PLT25x320 - Mkd F3

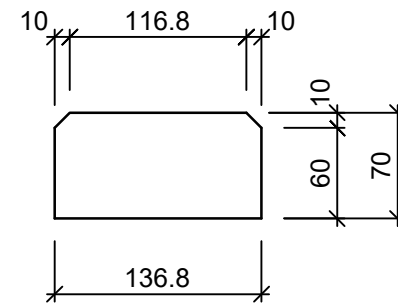

8 No. FL70x12 - Mkd F1

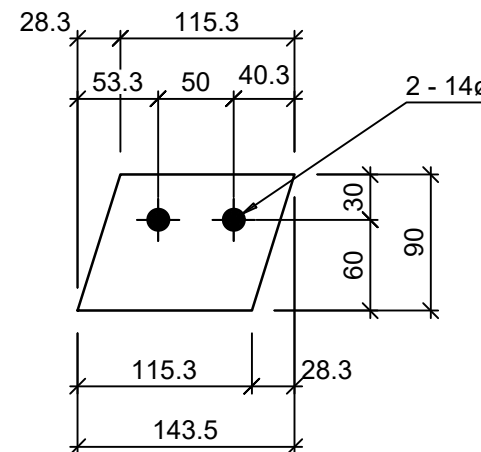

3 No. FL90X10 - Mkd F4

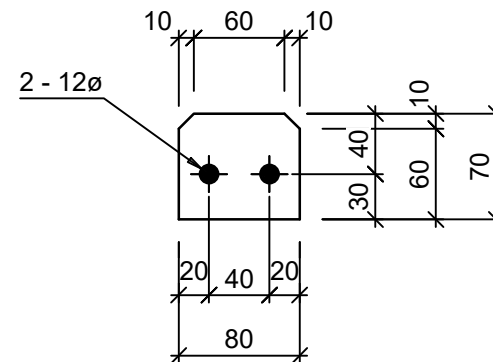

6 No. FL70X10 - Mkd F7

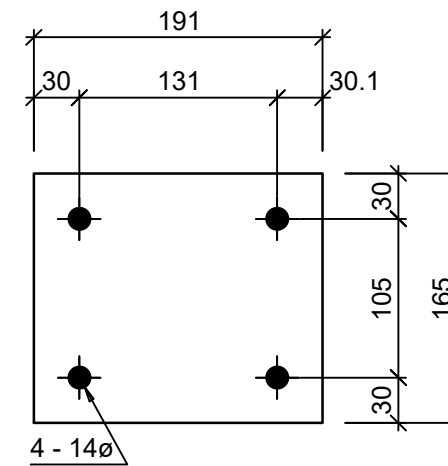

4 No. PLT12x165 - Mkd F5

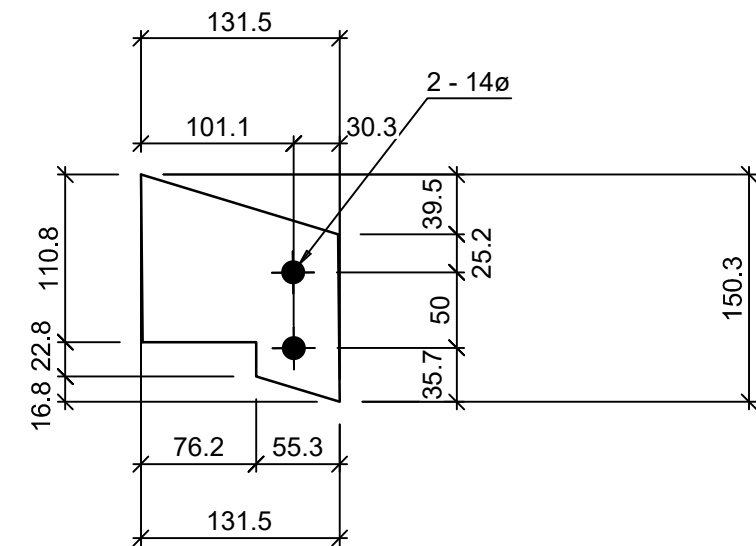

1 No. FL150X10 - Mkd F6

Mark	Quantity	Profile	Length	Material	Area (m ²)	Weight
F1	8	FL70x12	137	S275	0.02	0.89
F2	6	PLT10x147	310	S275	0.10	3.57
F3	4	PLT25x320	320	S275	0.24	20.10
F4	3	FL90X10	144	S275	0.02	0.81
F5	4	PLT12x165	191	S275	0.07	2.97
F6	1	FL150X10	131	S275	0.03	1.13
F7	6	FL70X10	80	S275	0.01	0.43
						127.00

Index	Date	Description	General Notes	Author
		CONTRACT 1. All holes 22Ø U.N.O. 2. This drawing must not be scaled.		
		DRAWN BY	DATE 17/2/2021	SCALE 1:5

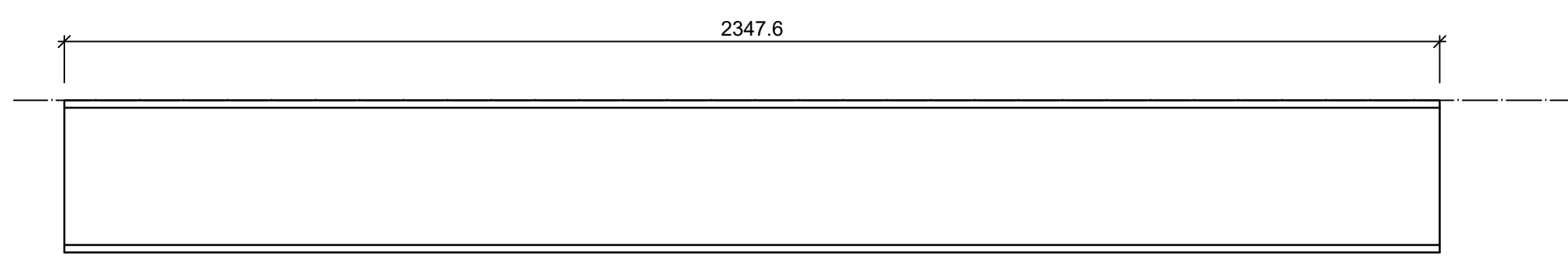

1 No. UB254x146x43 - Mkd M6

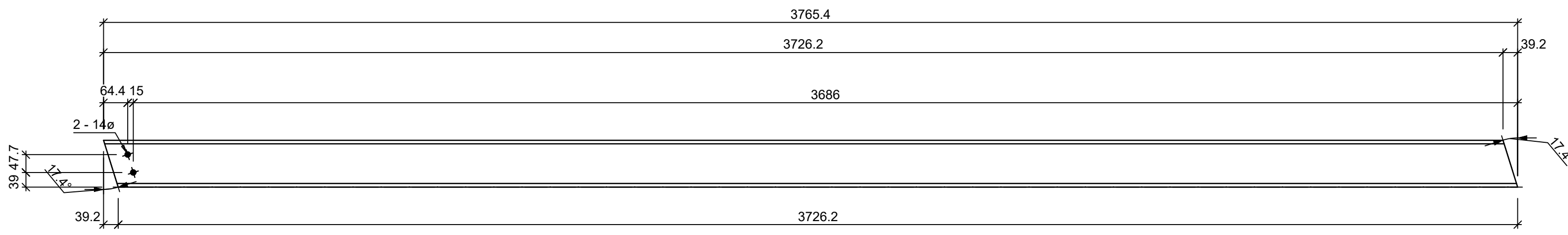

2 No. PFC125x65x15 - Mkd M3

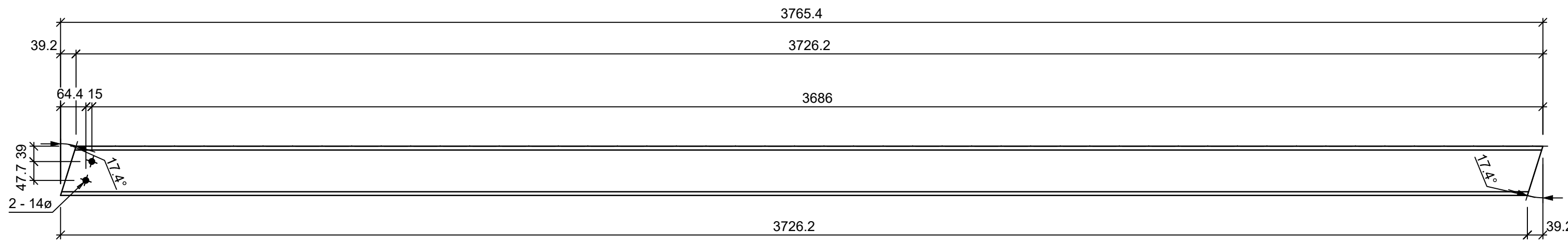

1 No. PFC125x65x15 - Mkd M5

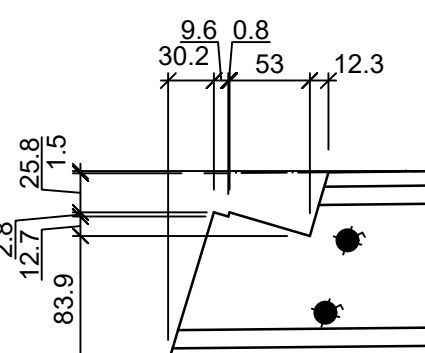

A DETAIL 103 Scale: 1:5

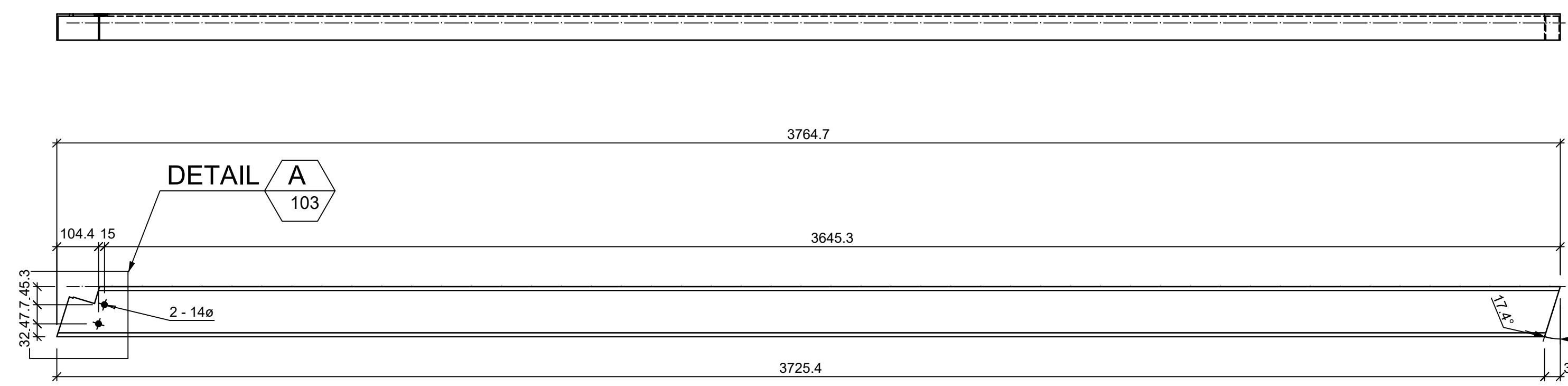

1 No. PFC125x65x15 - Mkd M4

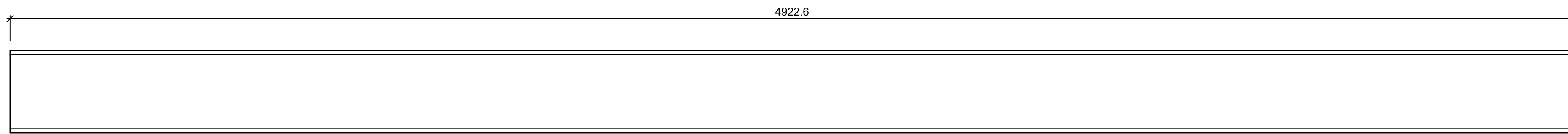

1 No. UB254x146x43 - Mkd M7

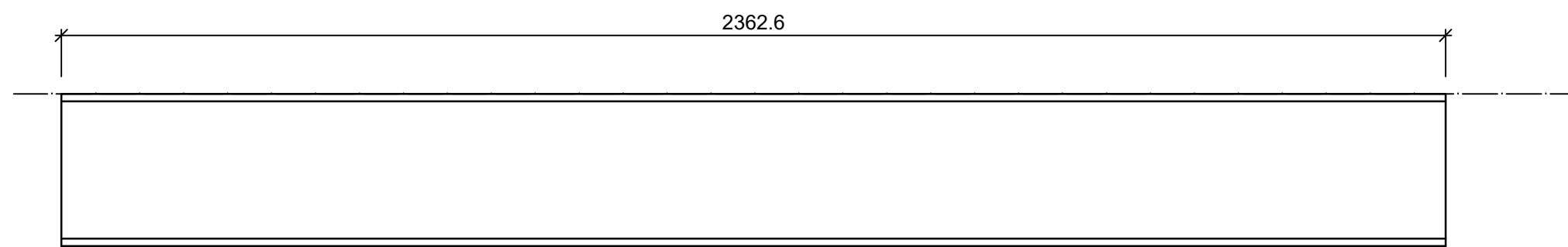

1 No. UB254x146x43 - Mkd M8

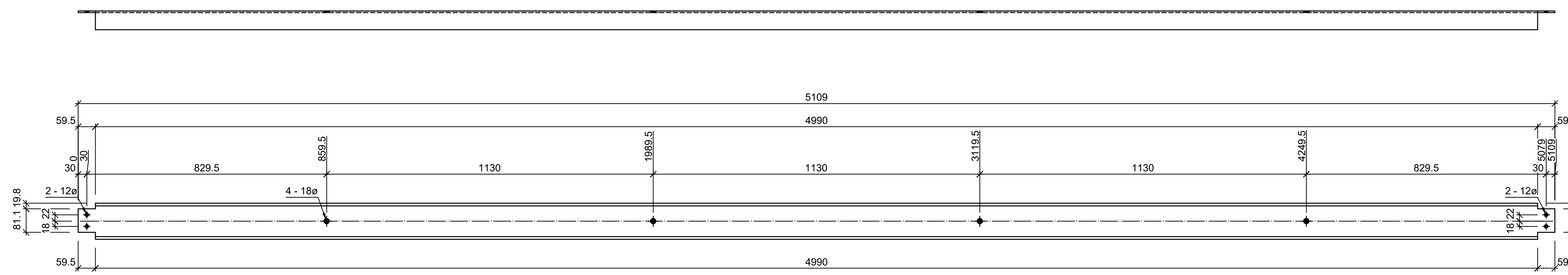
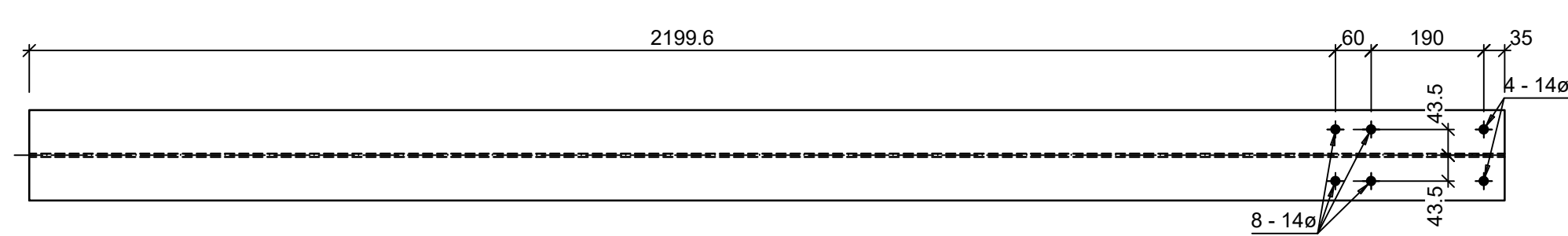

1 No. PFC125x65x15 - Mkd B3

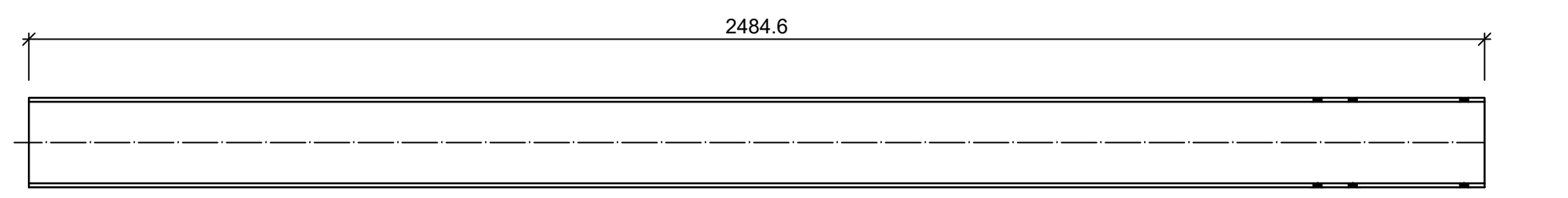

2 No. UC152x152x23 - Mkd M1

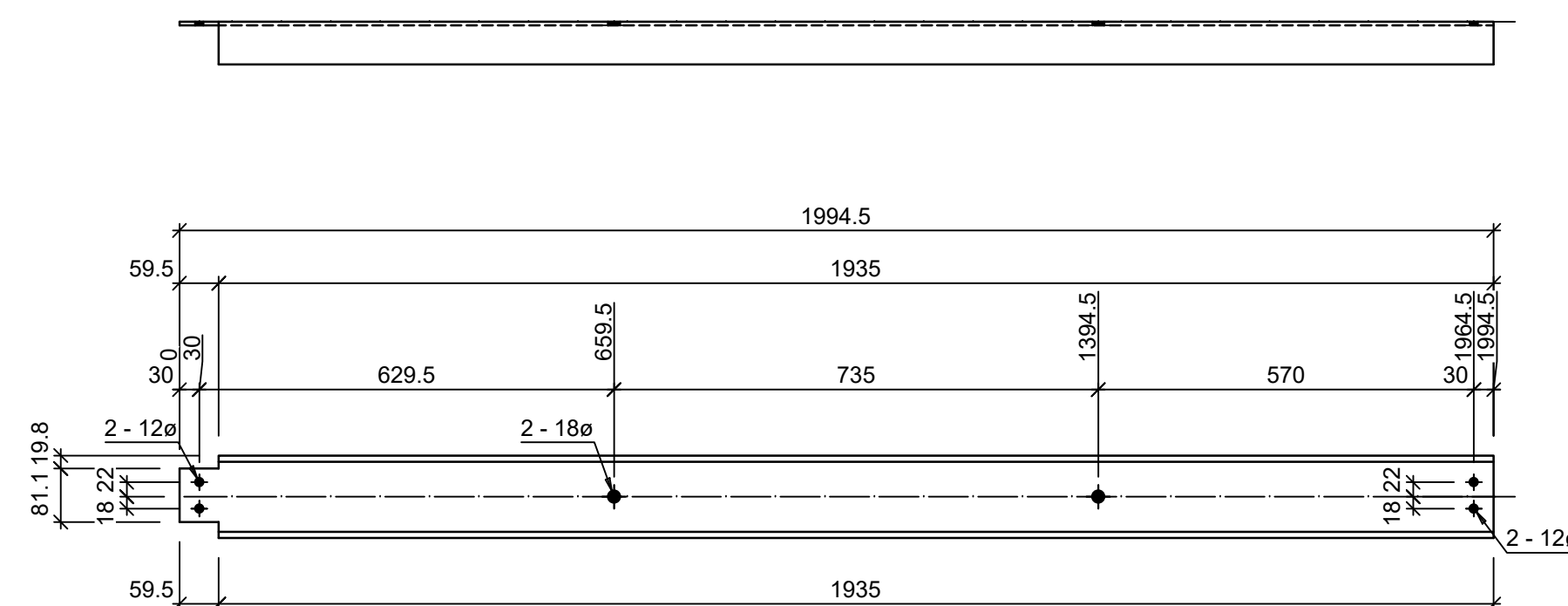
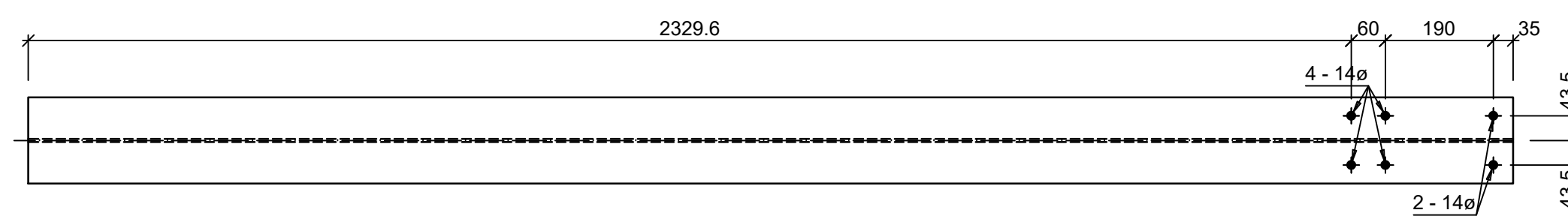

1 No. PFC125x65x15 - Mkd B1

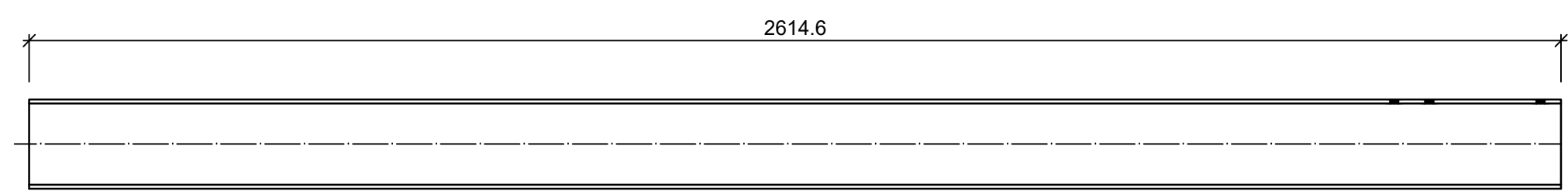

2 No. UC152x152x23 - Mkd M2

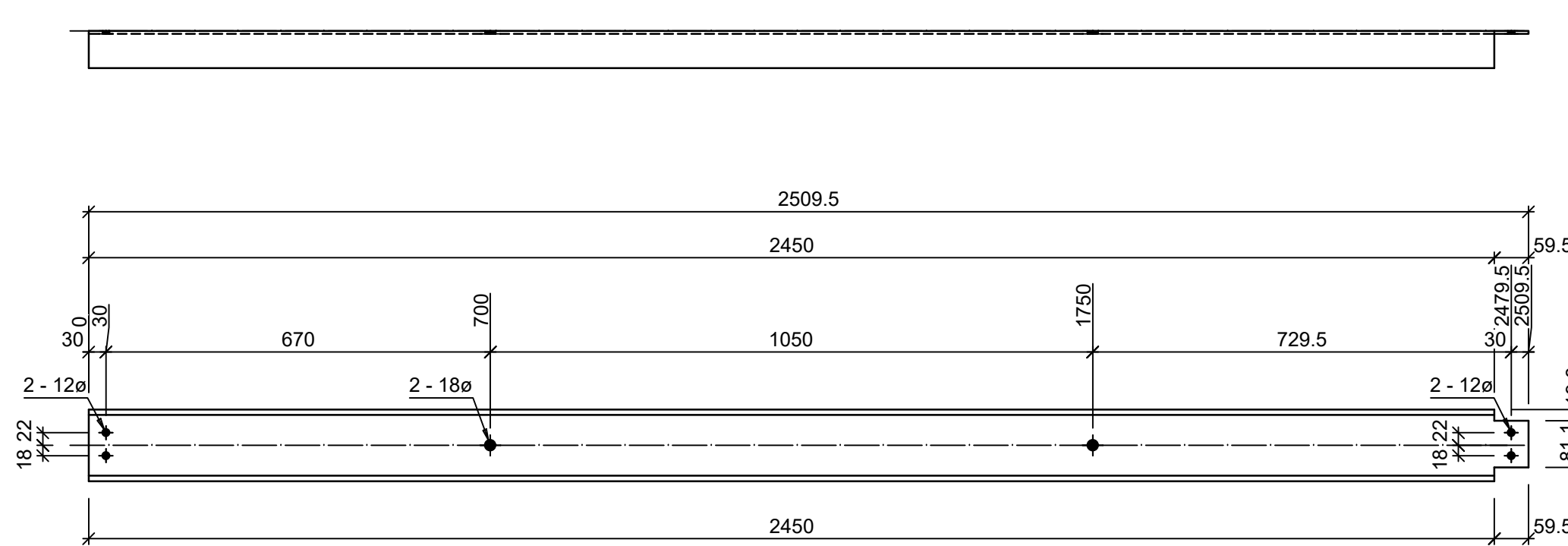

1 No. PFC125x65x15 - Mkd B8

Mark	Quantity	Profile	Length	Material	Area (m ²)	Weight
B1	1	PFC125x65x15	1994	S275	1.00	29.43
B3	1	PFC125x65x15	5109	S275	2.55	75.40
B8	1	PFC125x65x15	2509	S275	1.25	37.04
M1	2	UC152x152x23	2485	S275	2.24	57.15
M2	2	UC152x152x23	2615	S275	2.36	60.14
M3	2	PFC125x65x15	3765	S275	1.88	55.57
M4	1	PFC125x65x15	3765	S275	1.88	55.56
M5	1	PFC125x65x15	3765	S275	1.88	55.57
M6	1	UB254x146x43	2348	S275	2.57	100.99
M7	1	UB254x146x43	4923	S275	5.39	211.76
M8	1	UB254x146x43	2363	S275	2.58	101.63
						1013.08

Autodesk®

DRAWN BY

DATE

17/2/2021

SCALE

1:10,1:5

CONTRACT

JOB No.

DRG No.

[MS] 103

Rev.

Rev0

LOT	QTY
	1

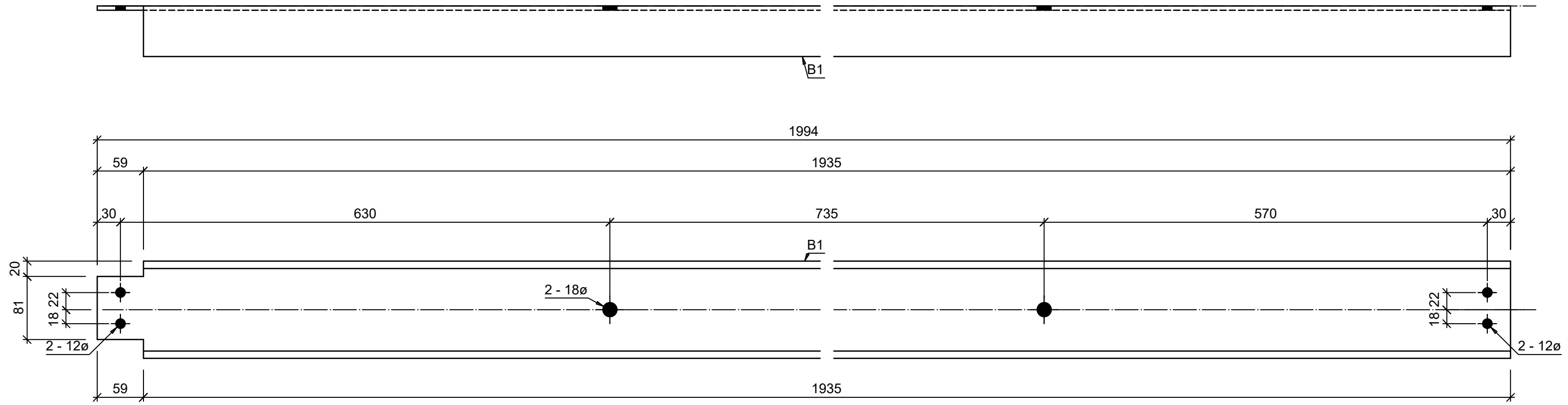

1 No. Mkd B1 (Coating as specified)

Mark	Quantity	Profile	Length	Material	Area (m ²)	Weight (kg)
B1	1	Values for ONE assembly				
B1	1	PFC125x65x15	1994.5	S275	1.00	29.43
Totals for ONE assembly					1.00	29.43

General Notes
 1. All holes 22Ø U.N.O.
 2. All welds continuous 6mm fillet U.N.O.
 3. This drawing must not be scaled.

Index	Date	Description	Author
		CONTRACT	
		DESCRIPTION	
		Beam	
DRAWN BY	DATE	SCALE	JOB No.
	17/2/2021	1:5	DRG No. [A] - B1
			Rev. Rev0

Autodesk®

LOT	QTY
	1

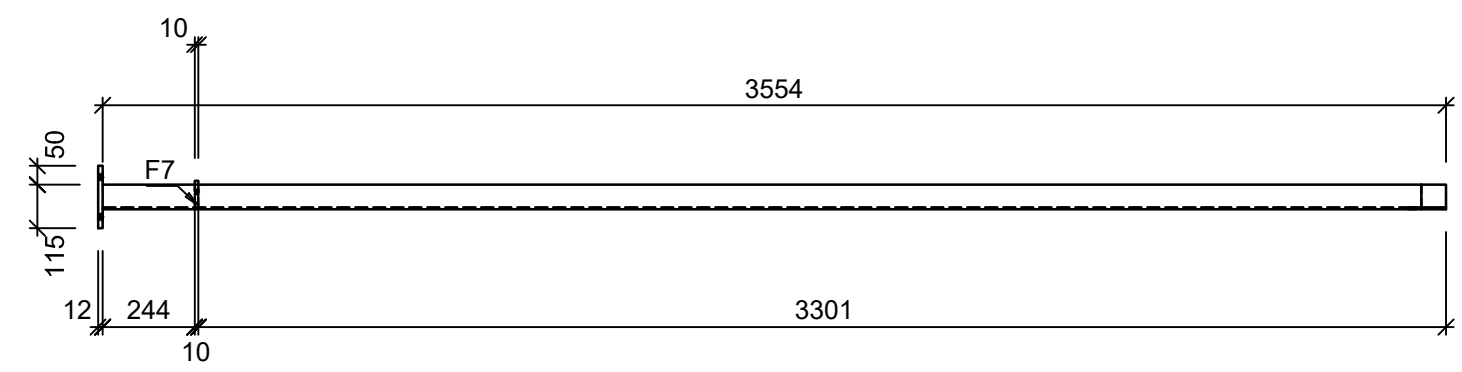
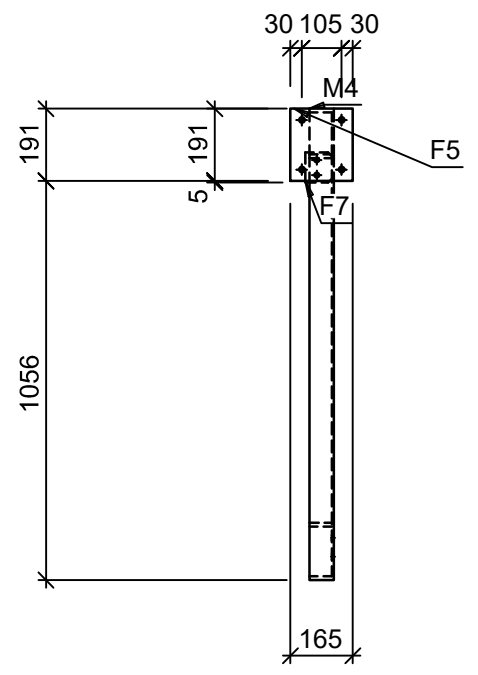

A - A

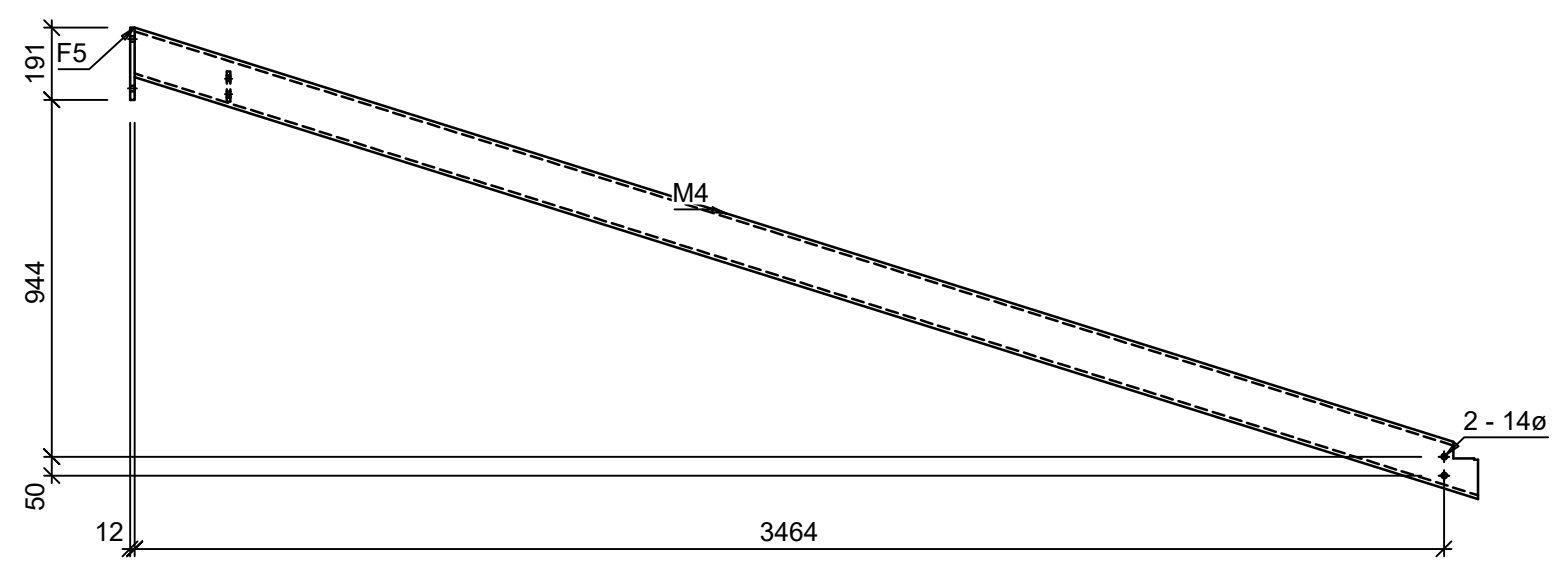

A

A

1 No. Mkd B2 (Coating as specified)

Mark	Quantity	Profile	Length	Material	Area (m ²)	Weight (kg)
B2	1	Values for ONE assembly				
F5	1	PLT12x165	191.0	S275	0.07	2.97
F7	1	FL70X10	80.0	S275	0.01	0.43
M4	1	PFC125x65x15	3764.7	S275	1.88	55.56
Totals for ONE assembly					1.96	58.96

- General Notes**
1. All holes 22Ø U.N.O.
 2. All welds continuous 6mm fillet U.N.O.
 3. This drawing must not be scaled.

Index	Date	Description	Author
		CONTRACT	
		DESCRIPTION	
		Base Plate	
DRAWN BY	DATE	SCALE	JOB No.
	14/2/2021	1:20	DRG No. [A] - B2
			Rev. Rev0

Autodesk®

LOT	QTY
	1

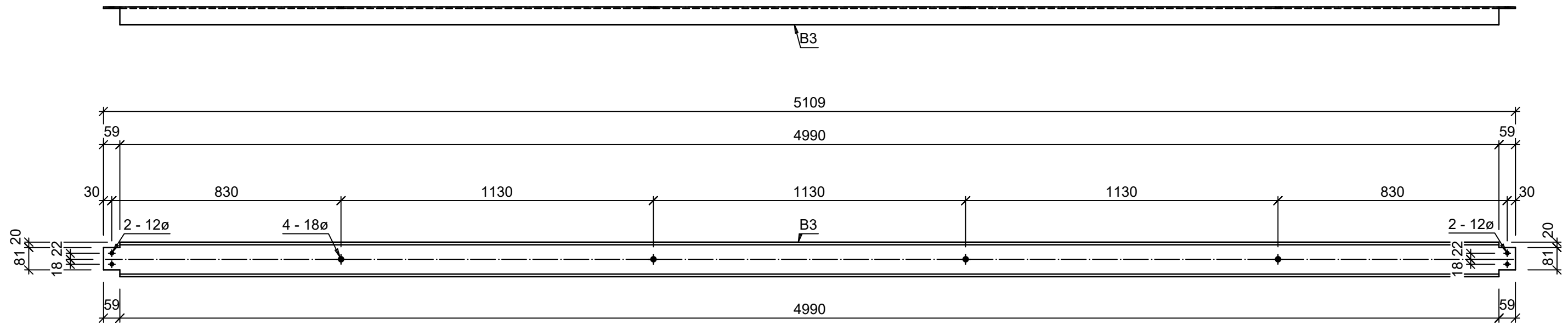

1 No. Mkd B3 (Coating as specified)

Mark	Quantity	Profile	Length	Material	Area (m ²)	Weight (kg)
B3	1	Values for ONE assembly				
B3	1	PFC125x65x15	5109.0	S275	2.55	75.40
Totals for ONE assembly					2.55	75.40

General Notes

1. All holes 22Ø U.N.O.
2. All welds continuous 6mm fillet U.N.O.
3. This drawing must not be scaled.

Index	Date	Description	Author
		CONTRACT	
		DESCRIPTION	
		Beam	
DRAWN BY	DATE	SCALE	JOB No.
	17/2/2021	1:15	DRG No. [A] - B3
			Rev. Rev0

Autodesk®

LOT	QTY
	1

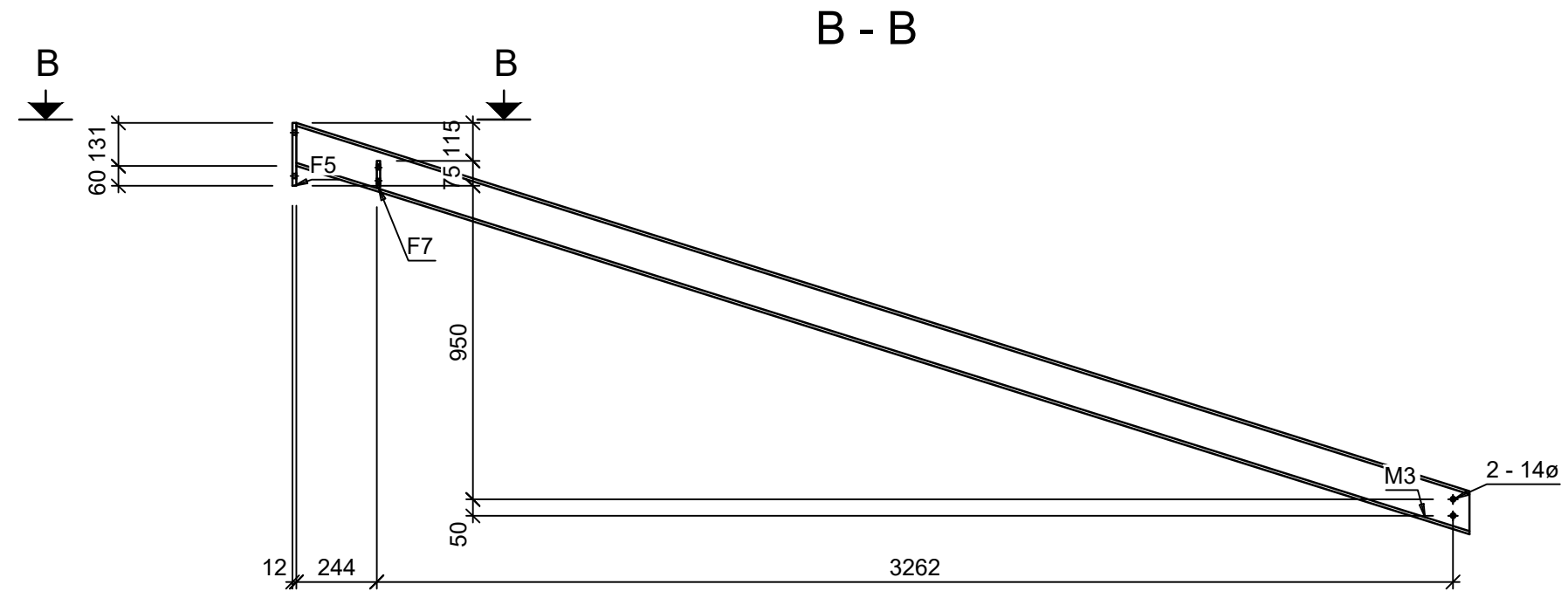
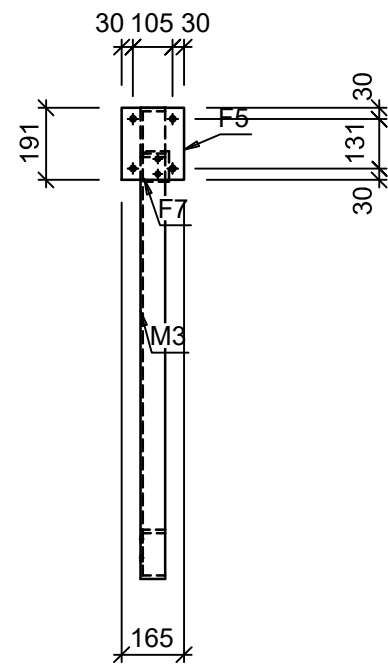
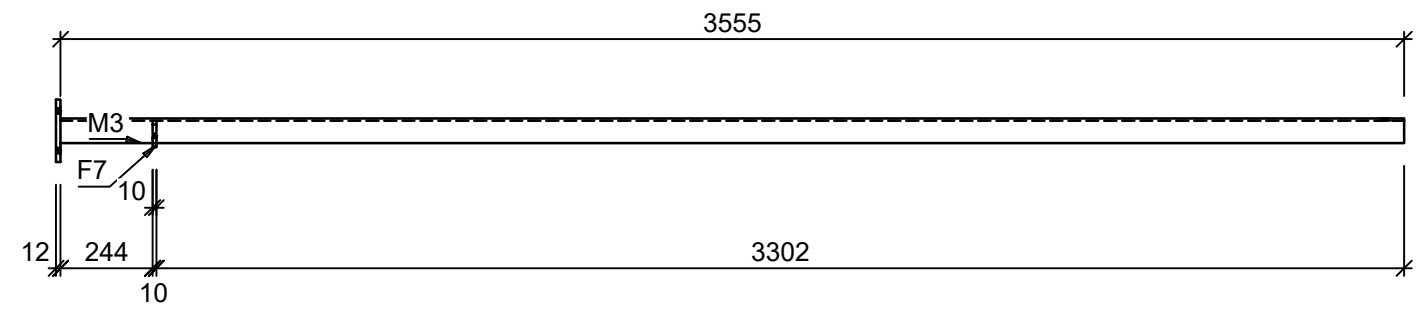

1 No. Mkd B4 (Coating as specified)

Mark	Quantity	Profile	Length	Material	Area (m ²)	Weight (kg)
B4	1	Values for ONE assembly				
F5	1	PLT12x165	191.0	S275	0.07	2.97
F7	1	FL70X10	80.0	S275	0.01	0.43
M3	1	PFC125x65x15	3765.4	S275	1.88	55.57
Totals for ONE assembly					1.96	58.97

- General Notes**
- All holes 22Ø U.N.O.
 - All welds continuous 6mm fillet U.N.O.
 - This drawing must not be scaled.

Index	Date	Description	Author
Autodesk®		CONTRACT	
		DESCRIPTION Base Plate	
DRAWN BY	DATE 14/2/2021	SCALE 1:20	Rev. Rev0
		JOB No.	DRG No. [A] - B4

LOT	QTY
	1

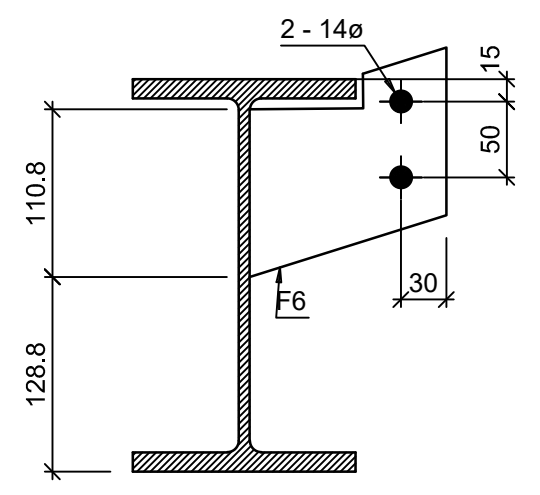
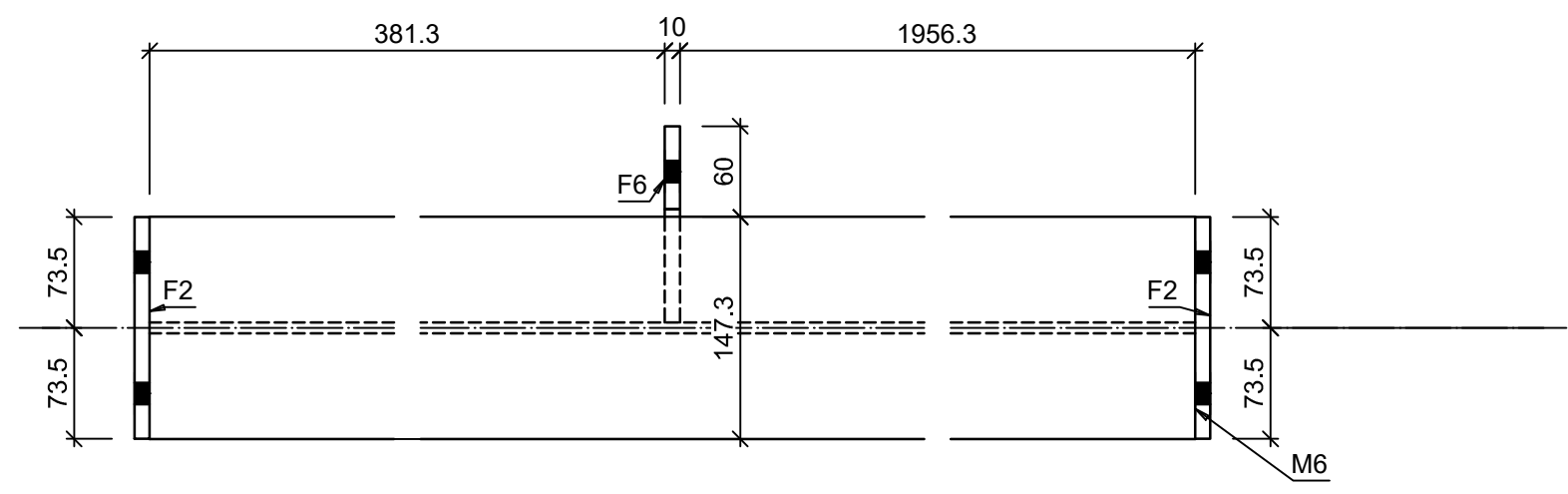

← A

A - A

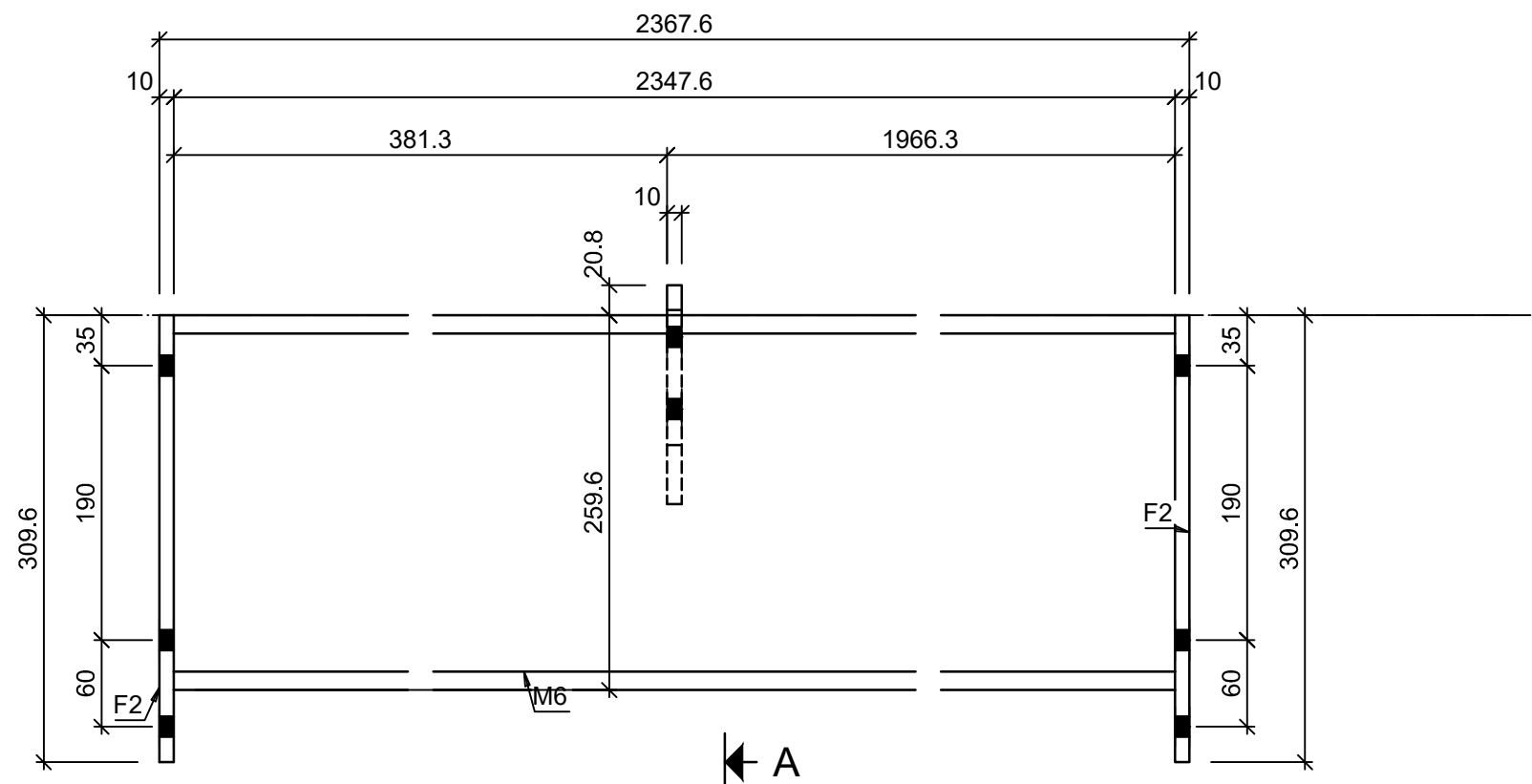
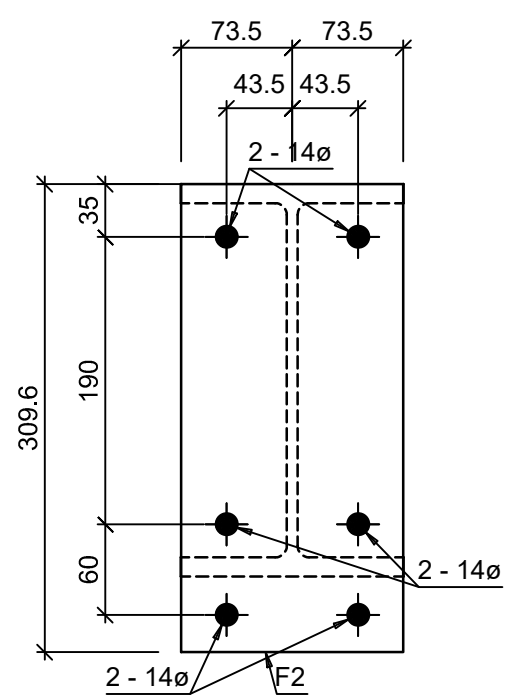

← A

1 No. Mkd B5 (Coating as specified)

Mark	Quantity	Profile	Length	Material	Area (m ²)	Weight (kg)
B5	1	Values for ONE assembly				
M6	1	UB254x146x43	2347.6	S275	2.57	100.99
F2	2	PLT10x147	309.6	S275	0.10	7.15
F6	1	FL150X10	131.5	S275	0.03	1.13
Totals for ONE assembly					2.80	109.27

- General Notes**
1. All holes 22Ø U.N.O.
 2. All welds continuous 6mm fillet U.N.O.
 3. This drawing must not be scaled.

Index	Date	Description	Author
		CONTRACT	
		DESCRIPTION	
		Beam	
DRAWN BY	DATE	SCALE	JOB No.
	14/2/2021	1:5	DRG No. [A] - B5
			Rev. Rev0

Autodesk®

LOT	QTY
	1

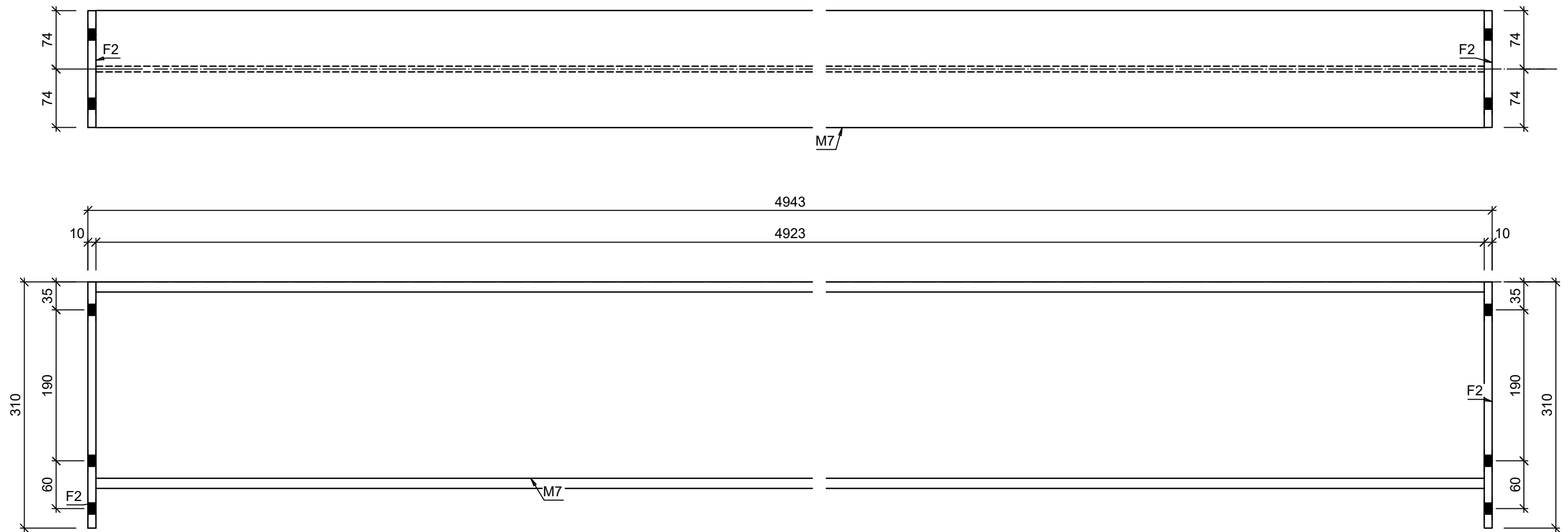

1 No. Mkd B6 (Coating as specified)

Mark	Quantity	Profile	Length	Material	Area (m ²)	Weight (kg)
B6	1	Values for ONE assembly				
M7	1	UB254x146x43	4922.6	S275	5.39	211.76
F2	2	PLT10x147	309.6	S275	0.10	7.15
Totals for ONE assembly					5.59	218.91

General Notes			Index	Date	Description	Author
1. All holes 22Ø U.N.O. 2. All welds continuous 6mm fillet U.N.O. 3. This drawing must not be scaled.					CONTRACT	
			Autodesk®		DESCRIPTION	
			DRAWN BY	DATE	SCALE	Rev.
				14/2/2021	1:5	Rev0
			JOB No.		DRG No.	
					[A] - B6	

LOT	QTY
	1

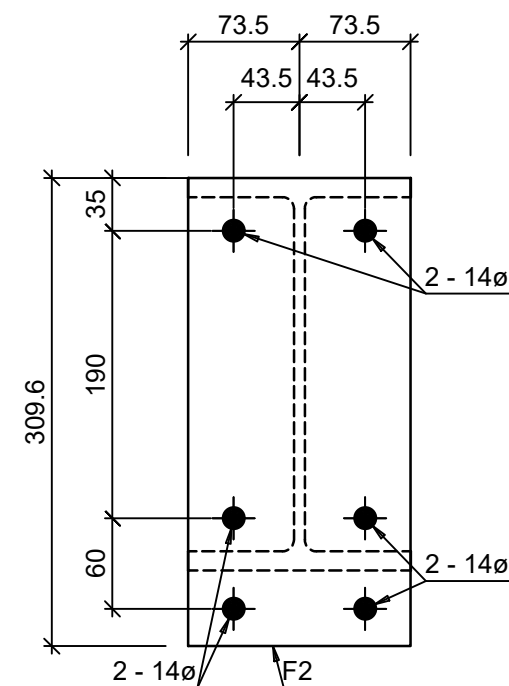
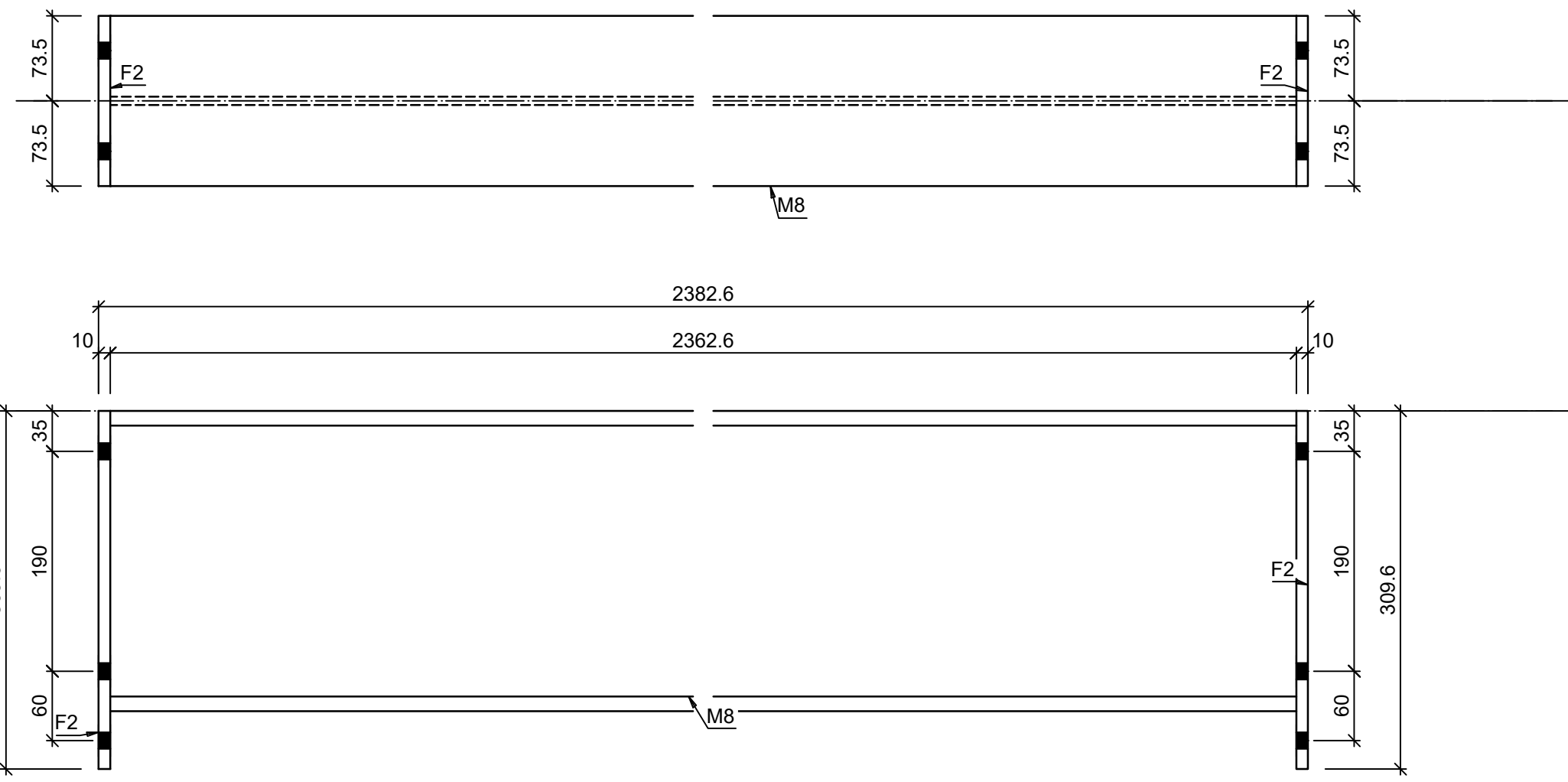

1 No. Mkd B7 (Coating as specified)

Mark	Quantity	Profile	Length	Material	Area (m ²)	Weight (kg)
B7	1	Values for ONE assembly				
M8	1	UB254x146x43	2362.6	S275	2.58	101.63
F2	2	PLT10x147	309.6	S275	0.10	7.15
Totals for ONE assembly					2.78	108.78

General Notes

1. All holes 22Ø U.N.O.
2. All welds continuous 6mm fillet U.N.O.
3. This drawing must not be scaled.

Index	Date	Description	Author
		CONTRACT	
		DESCRIPTION	
		Beam	
DRAWN BY	DATE	SCALE	JOB No.
	14/2/2021	1:5	DRG No. [A] - B7
			Rev. Rev0

Autodesk®

LOT	QTY
	1

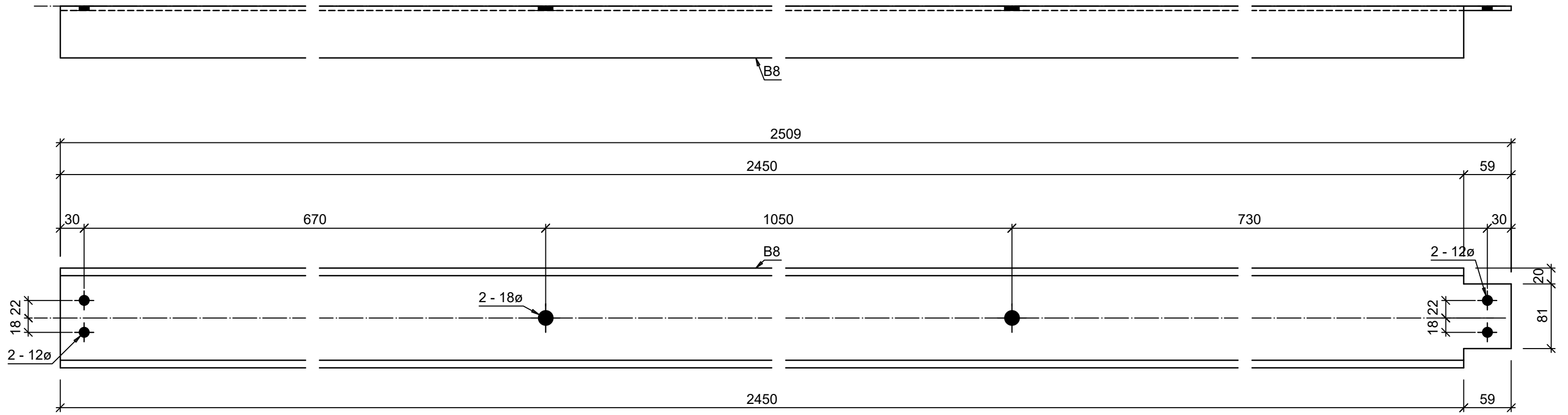

1 No. Mkd B8 (Coating as specified)

Mark	Quantity	Profile	Length	Material	Area (m ²)	Weight (kg)
B8	1	Values for ONE assembly				
B8	1	PFC125x65x15	2509.5	S275	1.25	37.04
Totals for ONE assembly					1.25	37.04

General Notes
 1. All holes 22Ø U.N.O.
 2. All welds continuous 6mm fillet U.N.O.
 3. This drawing must not be scaled.

Index	Date	Description	Author
		CONTRACT	
		DESCRIPTION	
		Beam	
DRAWN BY	DATE	SCALE	JOB No.
	17/2/2021	1:5	DRG No. [A] - B8
			Rev. Rev0



LOT	QTY
	1

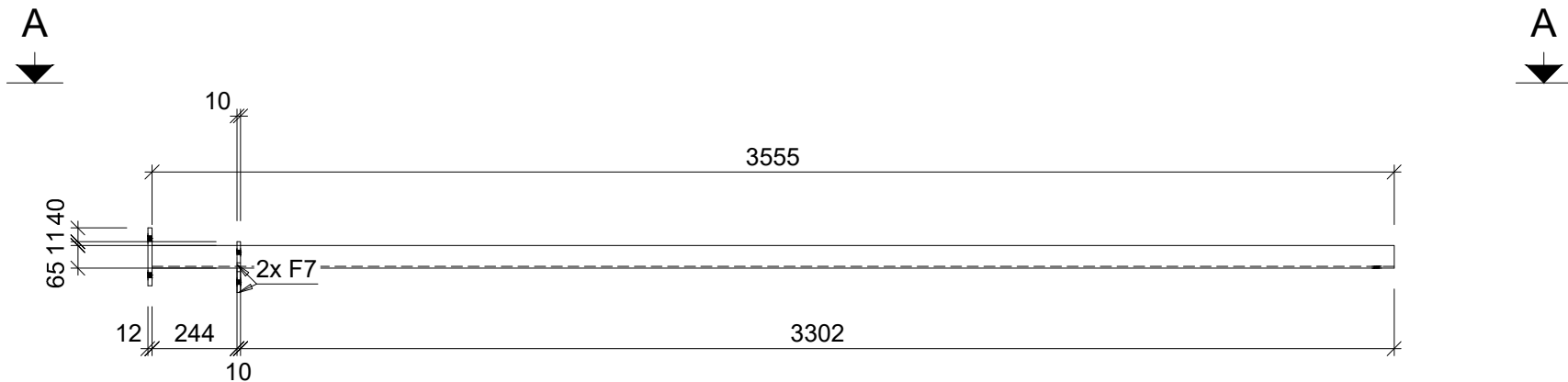
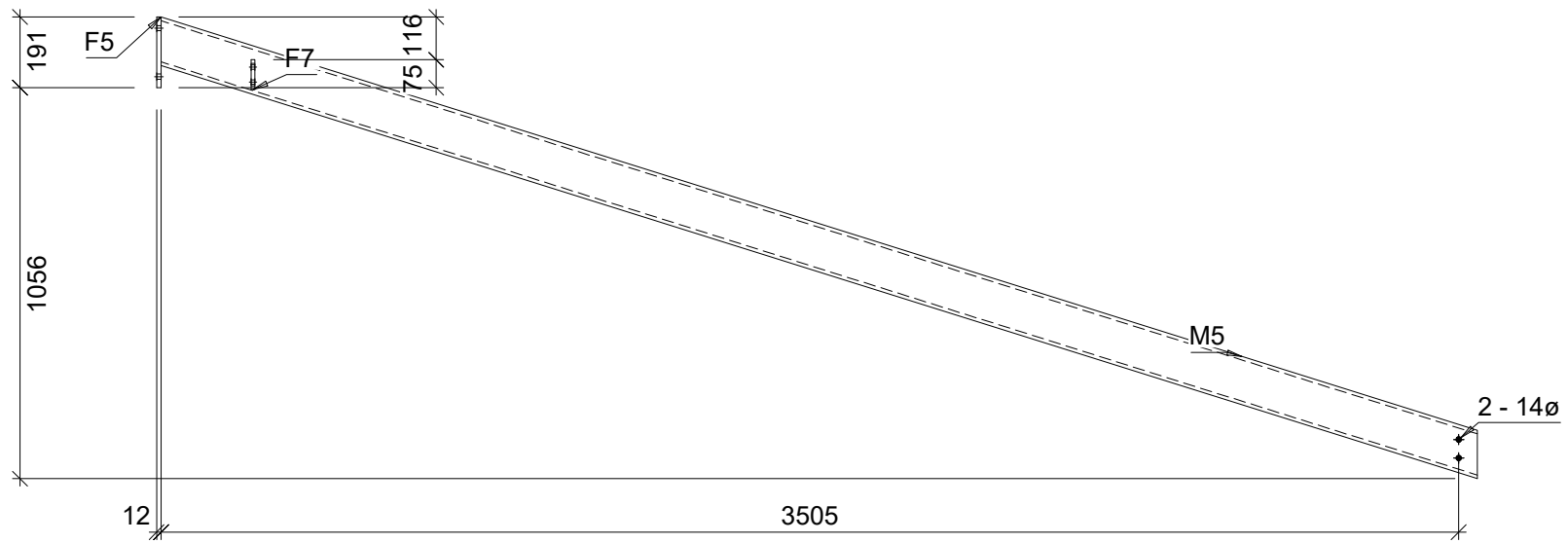
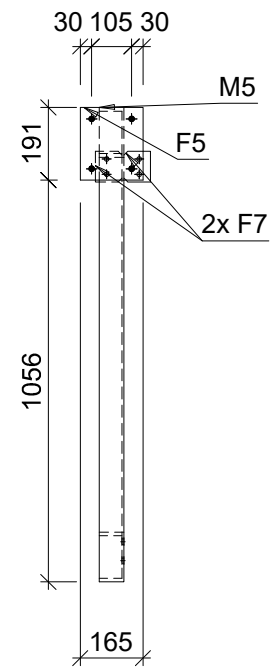

A - A

1 No. Mkd B10 (Coating as specified)

Mark	Quantity	Profile	Length	Material	Area (m ²)	Weight (kg)
B10	1	Values for ONE assembly				
F5	1	PLT12x165	191.0	S275	0.07	2.97
F7	2	FL70X10	80.0	S275	0.01	0.86
M5	1	PFC125x65x15	3765.4	S275	1.88	55.57
Totals for ONE assembly					1.98	59.40

General Notes

1. All holes 22Ø U.N.O.
2. All welds continuous 6mm fillet U.N.O.
3. This drawing must not be scaled.

Index	Date	Description	Author
		CONTRACT	
		DESCRIPTION Base Plate	
DRAWN BY	DATE 14/2/2021	SCALE 1:20	JOB No. DRG No. [A] - B10
			Rev. Rev0

LOT	QTY
	1

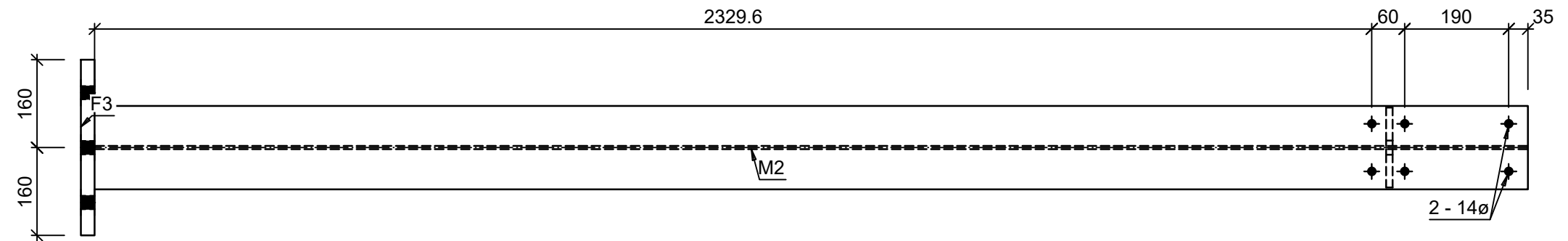

← B

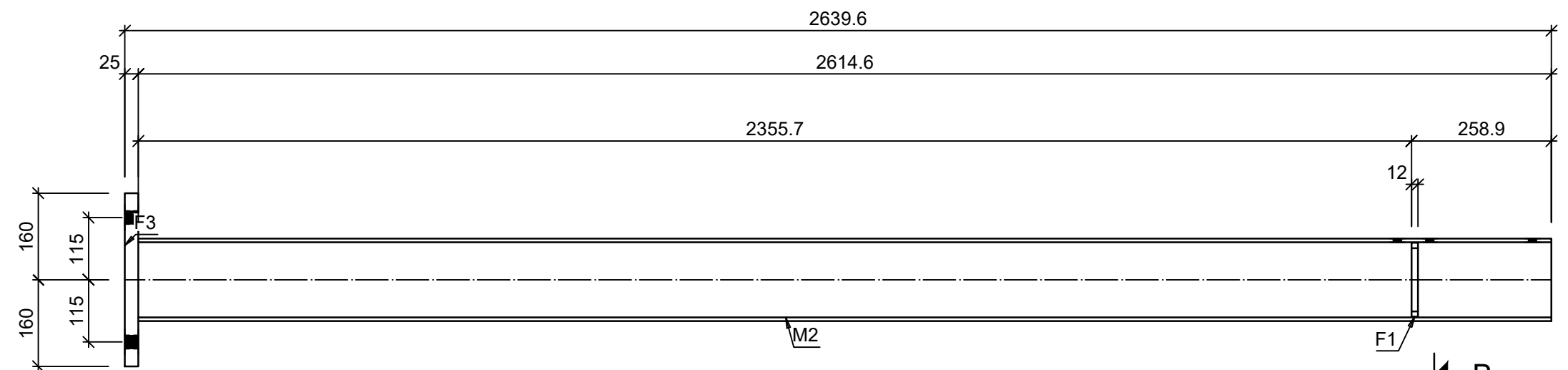

← B

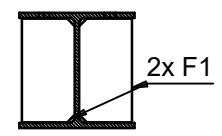

B - B

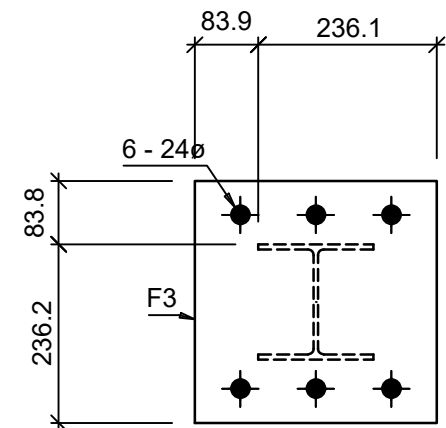

1 No. Mkd C1 (Coating as specified)

Mark	Quantity	Profile	Length	Material	Area (m ²)	Weight (kg)
C1	1	Values for ONE assembly				
M2	1	UC152x152x23	2614.6	S275	2.36	60.14
F1	2	FL70x12	136.8	S275	0.02	1.79
F3	1	PLT25x320	320.0	S275	0.24	20.10
Totals for ONE assembly					2.64	82.02

- General Notes**
1. All holes 22Ø U.N.O.
 2. All welds continuous 6mm fillet U.N.O.
 3. This drawing must not be scaled.

Index	Date	Description	Author
Autodesk®		CONTRACT	
		DESCRIPTION Column	
DRAWN BY	DATE 14/2/2021	SCALE 1:10	JOB No. DRG No. [A] - C1 Rev. Rev0

LOT	QTY
	1

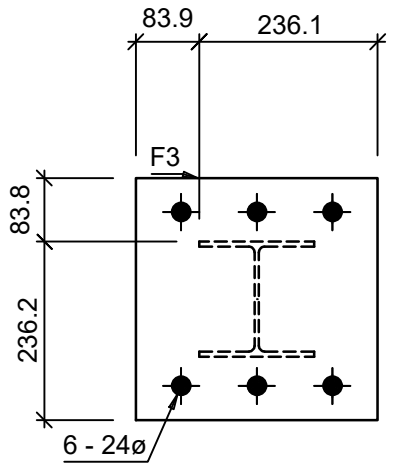
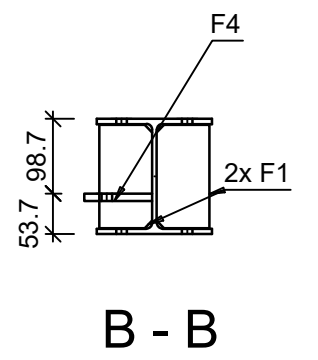
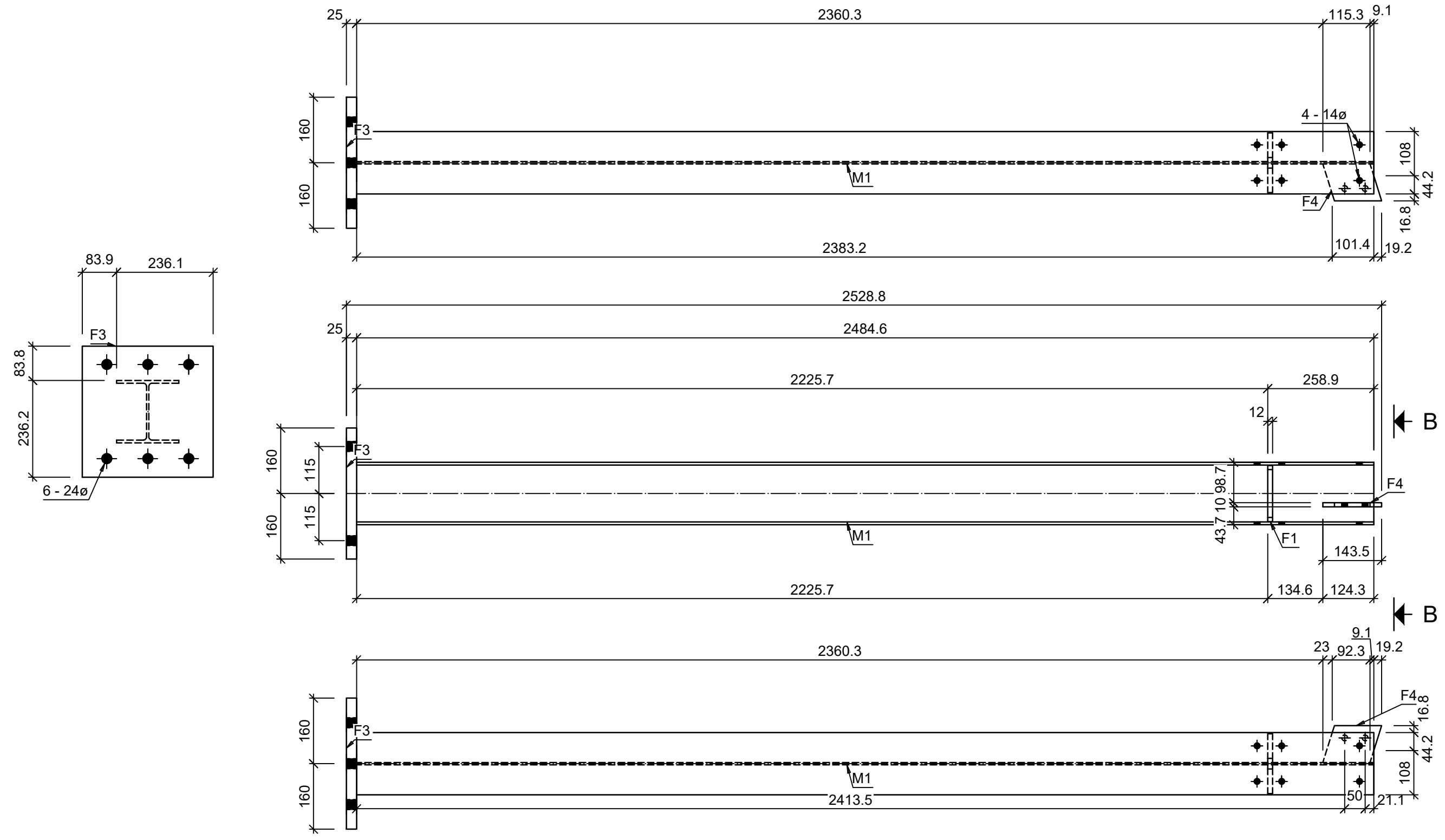

1 No. Mkd C2 (Coating as specified)

Mark	Quantity	Profile	Length	Material	Area (m ²)	Weight (kg)
C2	1	Values for ONE assembly				
M1	1	UC152x152x23	2484.6	S275	2.24	57.15
F1	2	FL70x12	136.8	S275	0.02	1.79
F3	1	PLT25x320	320.0	S275	0.24	20.10
F4	1	FL90X10	143.5	S275	0.02	0.81
Totals for ONE assembly					2.55	79.84

General Notes

- All holes 22Ø U.N.O.
- All welds continuous 6mm fillet U.N.O.
- This drawing must not be scaled.

Index	Date	Description	Author
		CONTRACT	
		DESCRIPTION	
		Column	
DRAWN BY	DATE	SCALE	JOB No.
	14/2/2021	1:10	DRG No. [A] - C2
			Rev. Rev0



LOT	QTY
	1

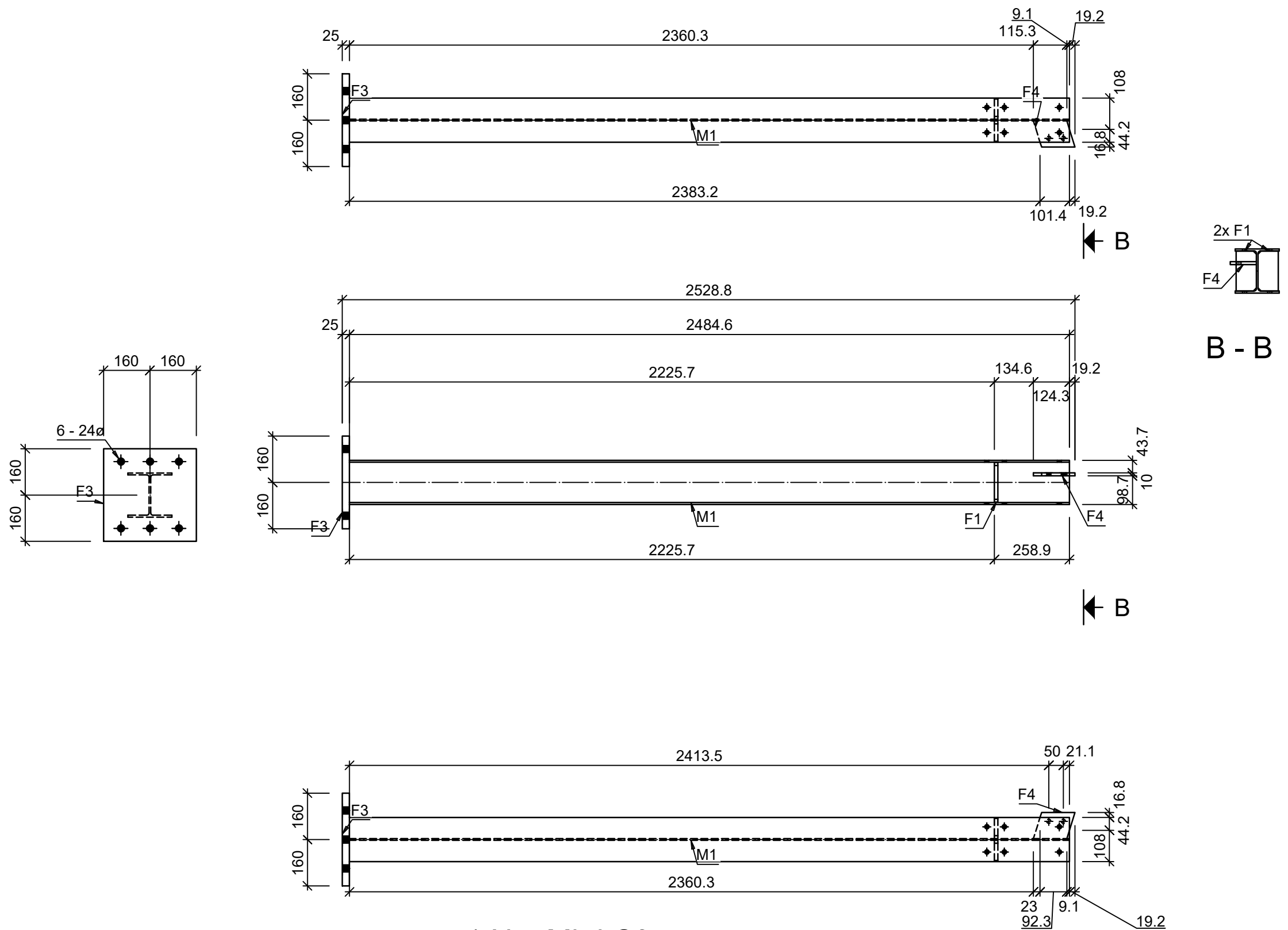

1 No. Mkd C3 (Coating as specified)

Mark	Quantity	Profile	Length	Material	Area (m ²)	Weight (kg)
C3	1	Values for ONE assembly				
M1	1	UC152x152x23	2484.6	S275	2.24	57.15
F1	2	FL70x12	136.8	S275	0.02	1.79
F3	1	PLT25x320	320.0	S275	0.24	20.10
F4	1	FL90X10	143.5	S275	0.02	0.81
Totals for ONE assembly					2.55	79.84

General Notes

- All holes 22Ø U.N.O.
- All welds continuous 6mm fillet U.N.O.
- This drawing must not be scaled.

Index	Date	Description	Author
		CONTRACT	
		DESCRIPTION	
		Column	
DRAWN BY	DATE	SCALE	JOB No.
	14/2/2021	1:15	DRG No. [A] - C3
			Rev. Rev0



LOT	QTY
	1

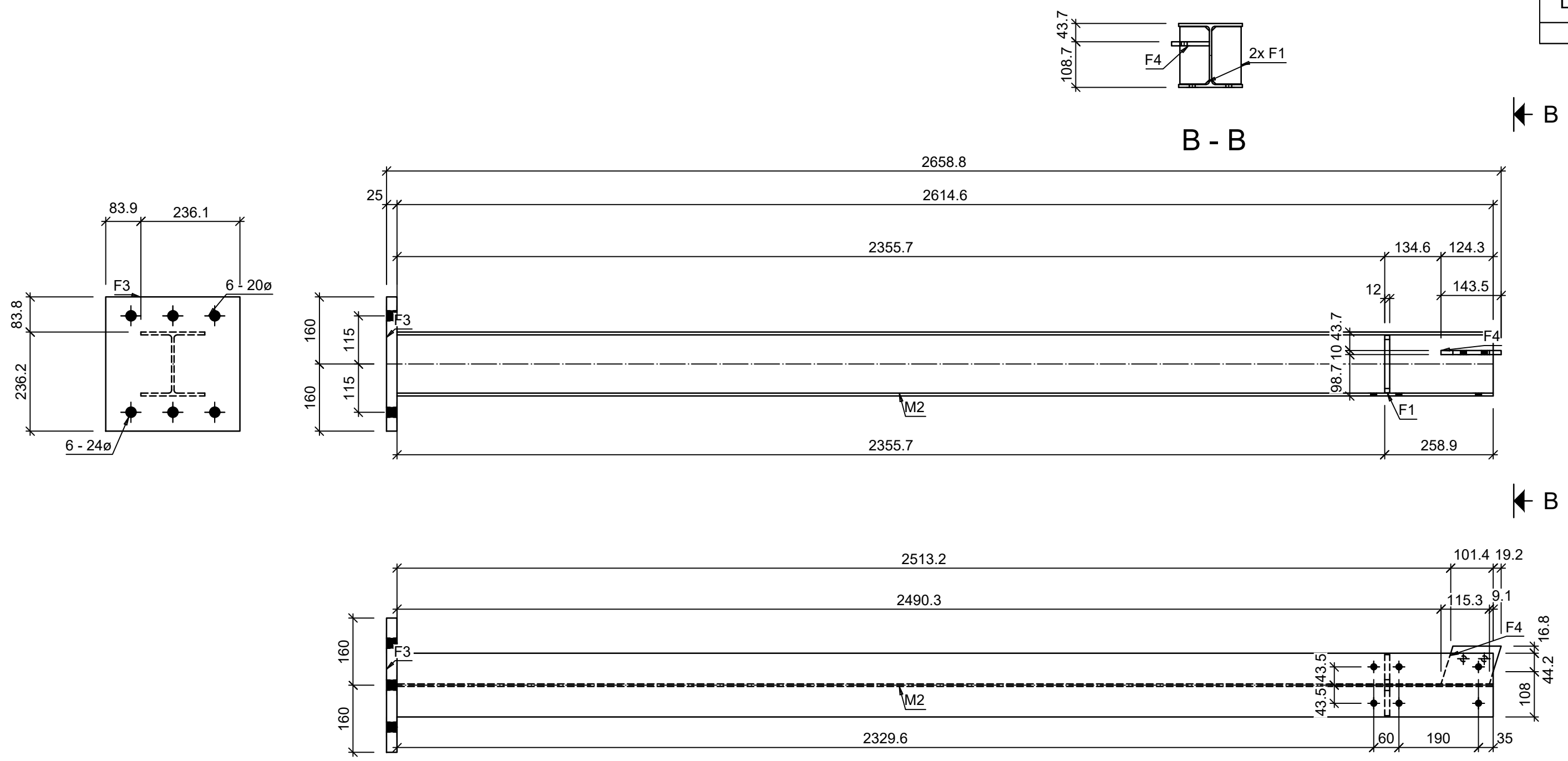

1 No. Mkd C4 (Coating as specified)

Mark	Quantity	Profile	Length	Material	Area (m ²)	Weight (kg)
C4	1	Values for ONE assembly				
M2	1	UC152x152x23	2614.6	S275	2.36	60.14
F1	2	FL70x12	136.8	S275	0.02	1.79
F3	1	PLT25x320	320.0	S275	0.24	20.10
F4	1	FL90X10	143.5	S275	0.02	0.81
Totals for ONE assembly					2.67	82.83

General Notes

- All holes 22 ϕ U.N.O.
- All welds continuous 6mm fillet U.N.O.
- This drawing must not be scaled.

Index	Date	Description	Author
		CONTRACT	
		DESCRIPTION	
		Column	
DRAWN BY	DATE	SCALE	JOB No.
	14/2/2021	1:10	
			DRG No.
			[A] - C4
			Rev.
			Rev0

